



TL46-W Contrast sensor

INSTRUCTION MANUAL

CONTROLS

OUT LED (yellow)

The red LED indicates the output status.

READY LED (green)

During functioning, the green LED permanently ON indicates a normal operating condition; fast blinking indicates an output overload condition.

(SET) PUSH-BUTTON (white)

The detection procedure is activated by pressing white (SET) push-button.

See the "SETTING" paragraph for setup procedure indications.



INSTALLATION

The sensor can be positioned by means the two Ø3.5mm housing's holes using or threaded M5 holes with 6mm max. depth.

Warning: the use of excessively long screws can damage the product.

The connector can be oriented at five different positions, rotating the block. The position chosen is guaranteed by a mechanical blocking system.

The rotation can be carried-out even after sensor installation as the connector block is completely self-contained inside the housing.



The operating distance is measured starting from the lens front face.

The reading direction can be changed inverting the cap and lens.

Mark detection on a reflective surface is improved adjusting the beam direction to 5° ... 20° from surface axis.

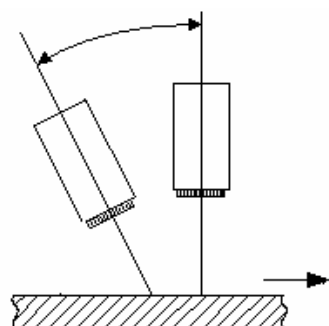

DIMENSIONS

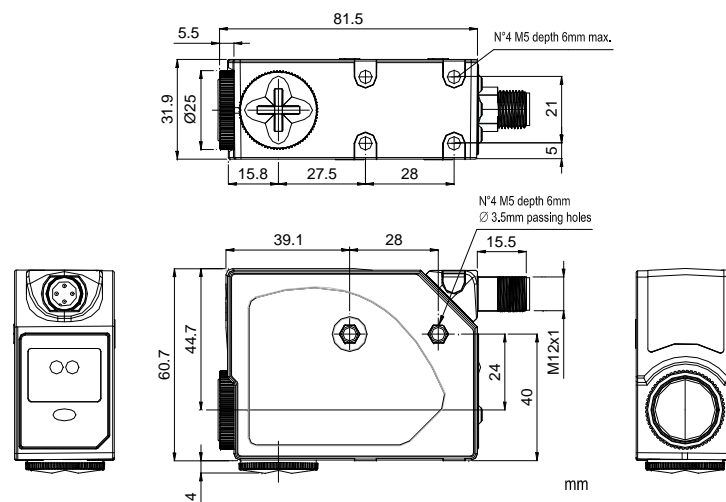

TECHNICAL DATA

Power supply:	10...30 Vdc limit values
Ripple:	2 Vpp max.
Current consumption (output current excluded):	50 mA max. @ 24Vcc
Output:	1 PNP/NPN selectable output 30 Vdc max. (short-circuit protection) (PNP is the default configuration)
Output current:	100 mA max.
Output saturation voltage:	≤ 2 V
Response time:	33 μs
Switching frequency:	15 kHz
Analogue output:	1 ... 3 V ± 10% (white 90%); 5.5 V max;
Analogue output impedance:	2.2 kΩ (short-circuit protection)
Delay:	0 / 20 ms selectable via delay input
Dark/light selection	automatic
Indicators:	OUT LED (yellow) / READY LED (green)
Operating temperature:	-10 ... 55 °C
Storage temperature:	-20 ... 70 °C
Electric shock protection:	double insulation <input type="checkbox"/>
Operating distance:	9 mm
Depth of field:	± 3 mm
Minimum spot dimension:	1.5x5 mm
Emission type:	blue (465 nm) / green (520 nm) / red (630 nm) with automatic selection
Ambient light rejection:	according to EN 60947-5-2
Vibrations:	0.5 mm amplitude, 10 ... 55 Hz frequency, for each axis (EN60068-2-6)
Shock resistance:	11 ms (30 G) 6 shock for each axis (EN60068-2-27)
Housing material:	aluminium
Lens material:	PMMA
Mechanical protection:	IP67
Connections:	M12 5-pole connector
Weight:	170 g. max.

CONNECTIONS

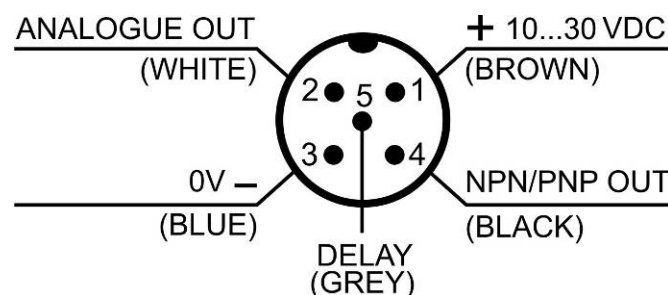

SETTING

DETECTION (MARK-BACKGROUND)

- Position mark in front of the sensor light spot and press white (SET) push-button until the READY LED (green) turns OFF.
- The sensor detects the mark alternating the red, green and blue emissions.
- Avoid mark movements during this phase.

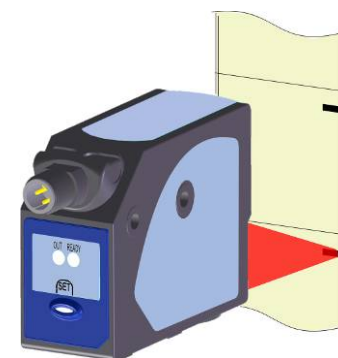

- Position the background in front of the sensor light spot and press white (SET) push-button again. The sensor detects the mark alternating the red, green and blue emissions. Avoid background movements during this phase.



The DARK/LIGHT operating mode is automatically selected by the sensor.
Dark mark - light background = dark mode; light mark - dark background = light mode.

If the READY LED is permanently ON, the detection is successful.
If the LED blinks slowly, the detection has failed due to insufficient contrast.
The sensor returns to the previous setting by pressing white (SET) push-button.
Repeat the procedure from the beginning.

PNP/NPN OUTPUT SETTING

The digital output can be PNP or NPN configured.

- To change output press white (SET) push-button for 10 sec.
- The setting is signalled by the status change of the READY LED.
- If the READY LED turns off after a 1 sec. pressure, release push-button only after the re-powering of the LED (10sec).
- The output setting is signalled by the READY LED. Releasing the push-button, the READY LED blinks once if the PNP output is set, blinks twice if the NPN output is set.

Ⓢ 1 sec pressure of (SET)	Ⓢ 10 sec pressure of (SET)	Release of push-buttons
● ●	● ●	● ✨

OUTPUT OVERLOAD

The digital output overload is signalled by the rapid blinking of the READY LED.

ACCESSORY FUNCTIONS

ANALOGUE output

The analogue output supplies a voltage proportional to the signal received by the sensor. The voltage supplied is 1 ÷ 5.5V.
The maximum voltage is obtained with reflective objects; on 90% white the voltage is equal to 3V.

DELAY SETTING

The DELAY extends to 20ms the minimum duration of the active output allowing the slower interfacing systems to detect shorter pulses.

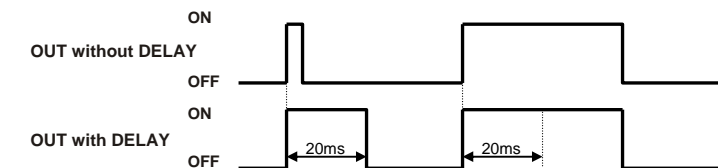

Delay activation

- Connect Delay signal (grey wire) to power supply.

Delay deactivation

- Connect Delay signal (grey wire) to 0V or leave unconnected.

	EX-II-3DG IP67 T6
	Temperature class: T6 (<85°C)
	Max. Power consumption 1500 mW at 30 Vdc
	Max. Internal capacitance 450 pF
	Internal inductance: negligible

DECLARATION OF CONFORMITY

We DATASENSOR S.p.A. declare under our sole responsibility that these products are conform to the 2004/108/CE, 2006/95/CE Directives and successive amendments.

WARRANTY

DATASENSOR S.p.A. warrants its products to be free from defects.
DATASENSOR S.p.A. will repair or replace, free of charge, any product found to be defective during the warranty period of 36 months from the manufacturing date.
This warranty does not cover damage or liability deriving from the improper application of DATASENSOR products.

DATASENSOR S.p.A. Via Lavino 265
40050 Monte S. Pietro - Bologna - Italy
Tel: +39 051 6765611 Fax: +39 051 6759324
http://www.datasensor.com e-mail: info@datasensor.com

DATASENSOR S.p.A. cares for the environment: 100% recycled paper.
DATASENSOR S.p.A. reserves the right to make modifications and improvements without prior notification.



INSTRUCTION MANUAL

CONTROLS

OUT LED (yellow)
The yellow LED indicates the output status.

READY LED (green)
During functioning, the green LED permanently ON indicates a normal operating condition.
Fast blinking indicates an output overload condition.

DELAY LED (orange)
The orange DELAY LED ON indicates the timing function activation on the digital output.

KEYLOCK LED (orange)
The orange KEYLOCK LED ON indicates the active keyboard status.

BARGRAPH
The switching threshold level is signalled on the bargraph.

SET PUSH-BUTTON (bianco)
The detection procedure is activated by pressing the SET push-button.

(+) (red) and (-) (green) PUSH-BUTTONS
The threshold adjustment procedure is activated by pressing the (+) and (-) push-buttons.

See the "SETTING" paragraph for the correct adjustment phase indications.



INSTALLATION

The sensor can be positioned by means the two Ø3.5mm housing's holes using or threaded M5 holes with 6mm max. depth.

Warning: the use of excessively long screws can damage the product.

The connector can be oriented at five different positions, rotating the block. The position chosen is guaranteed by a mechanical blocking system. The rotation can be carried-out even after sensor installation as the connector block is completely self-contained inside the housing.



The operating distance is measured starting from the lens front face. The reading direction can be changed inverting the cap and lens. Mark detection on a reflective surface is improved adjusting the beam direction to 5° ... 20° from surface axis.

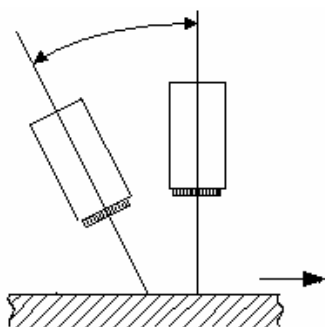

DIMENSIONS

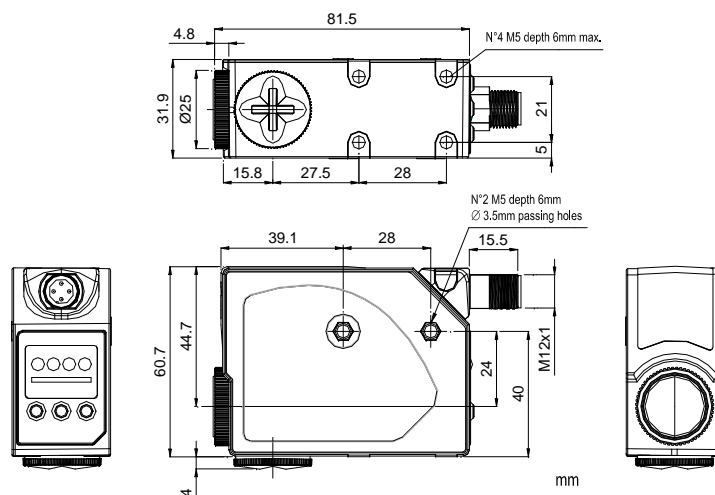

TECHNICAL DATA

Power supply:	10...30 Vdc (limit values)
Ripple:	2 Vpp max.
Current consumption (output current excluded):	85 mA max @ 24 Vdc with bargraph ON in threshold adjustment mode, 55 mA max @ 24 Vdc with bargraph OFF in normal functioning mode
Output:	1 selectable PNP/NPN output 30 Vdc max. (short-circuit protection) (default PNP configuration)
Output current:	100 mA max.
Output saturation voltage:	≤ 2 V
Response time:	25 μs
Switching frequency:	20 kHz
Analogue output:	1 ... 3 V ± 10% (90% white); 5.5 V max.
Analogue output impedance:	2.2 kΩ (short-circuit protection)
Delay	0 / 20ms selectable default configuration without delay
Dark/light selection:	Automatic
Indicators:	OUT LED (yellow) / READY LED (green) DELAY LED and KEYLOCK LED (orange) 5-segment bargraph
Operating temperature:	-10 ... 55 °C
Storage temperature:	-20 ... 70 °C
Electric shock protection:	double insulation
Operating distance:	9 mm
Depth of field:	± 3 mm
Minimum spot dimension:	1.5x5 mm
Emission type:	Blue (465 nm) / Green (520 nm) / Red (630 nm) with automatic selection
Ambient light rejection:	According to EN 60947-5-2
Vibrations:	0.5 mm amplitude, 10 ... 55 Hz frequency, for each axis (EN60068-2-6)
Shock resistance:	11 ms (30 G) 6 shock for each axis (EN60068-2-27)
Housing material:	Aluminium
Lens material:	Glass (*)
Mechanical protection:	IP67
Connections:	M12 5-pole connector
Weight:	170 g. max.

(*) It's available on request, PMMA plastic lens with 9mm focus.

CONNECTIONS

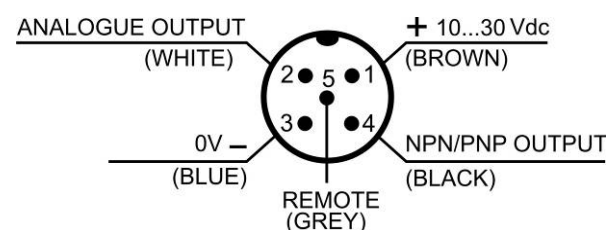

SETTING

KEYLOCK FUNCTION (PATENT-COVERED)

The KEYLOCK function deactivates the keyboard avoiding any accidental changes in sensor setting.

At sensor powering, the keyboard is blocked (KEYLOCK LED OFF).

The white (SET) push-button has to be pressed for 5 sec. until the KEYLOCK LED (orange) turns ON. The keyboard is blocked automatically if not used for 2 minutes.

The keyboard has to be unlocked to proceed with sensor setting.



DETECTION (MARK-BACKGROUND)

- Position mark in front of the sensor light spot and press white (SET) push-button until the READY LED (green) turns OFF.

The sensor detects the mark alternating the red, green and blue emissions; avoid mark movements during this phase.

- Position the background in front of the sensor light spot and press white (SET) push-button again. The sensor detects the mark alternating the red, green and blue emissions. Avoid background movements during this phase.

The DARK/LIGHT operating mode is automatically selected by the sensor.

Dark mark - light background = dark mode; light mark - dark background = light mode.

If the READY LED is permanently ON, the detection is successful. If the LED blinks slowly, the detection has failed due to insufficient contrast. The sensor returns to the previous setting by pressing white (SET) push-button.

Repeat the procedure from the beginning.

SWITCHING THRESHOLD SETTING

The sensor switching threshold is adjusted by pressing the (+) or (-) push-buttons (respectively increasing or decreasing the value).

At the first pressure of the (+) or (-) push-buttons, the first three LEDs of the bargraph turn ON.



Increasing or decreasing the threshold, the right or left LEDs blink with a frequency proportional to the difference from the initial threshold value.

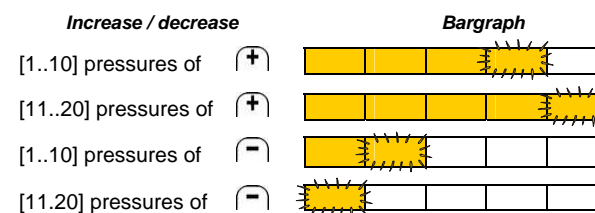

To save the new threshold value press white (SET) push-button or wait 30 sec. from last change (automatic save).

DELAY SETTING

The DELAY extends to 20ms the minimum duration of the active output allowing the slower interfacing systems to detect shorter pulses.

The active delay is signalled by the corresponding orange LED ON.

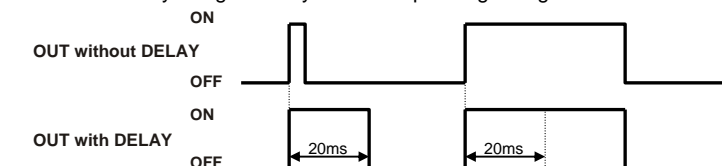

DELAY ACTIVATION

- Press (+) and (-) contemporaneously for 2 sec. until the DELAY LED turns ON.



DELAY DEACTIVATION

- Press (+) and (-) contemporaneously for 2 sec. until the DELAY LED turns OFF.



PNP/NPN OUTPUT SETTING

The digital output can be PNP or NPN configured.

- To change output press red (+) push-button and green (-) push-button contemporaneously for 10 sec.

- The setting is signalled by the status change of the DELAY LED.

If the delay is active after pressing the push-buttons for 2 seconds, the DELAY LED turns OFF, release the push-buttons only after LED re-powering (10 sec.).

If the delay is deactivated after pressing the push-buttons for 2 seconds, the DELAY LED turns ON, release the push-buttons only after LED turning off (10sec.).

- The output setting is signalled by the KEYLOCK LED. Releasing the push-buttons, the KEYLOCK LED blinks once if the PNP output is set, blinks twice if the NPN output is set.

	2 sec. pressure of (+) and (-)	10 sec. pressure of (+) and (-)	Release of push-buttons
Delay ON	[Green, Red, Blue]	[Green, Red, Blue]	[Green, Red, Blue]
Delay OFF	[Green, Red, Blue]	[Green, Red, Blue]	[Green, Red, Blue]

OUTPUT OVERLOAD

The digital output overload is signalled by the rapid blinking of the READY LED.

ACCESSORY FUNCTIONS

REMOTE INPUT

The REMOTE signals carries-out the acquisition functions without using the white (SET) push-button.

The REMOTE wire connected to +Vdc is equal to pressing the white (SET) push-button. Whereas, if the REMOTE wire is connected to GND or not connected it is equal to not pressing the white (SET) push-button.

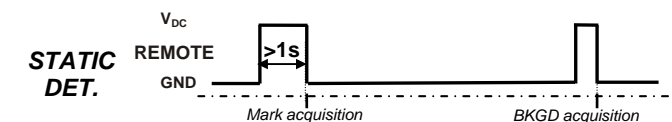

ANALOGUE OUTPUT

The analogue output supplies a voltage proportional to the signal received by the sensor. The voltage supplied is 1 ÷ 5.5V. The maximum voltage is obtained with reflective objects; on 90% white the voltage is equal to 3V.

	EX-II-3DG IP67 T6	
	Temperature class:	T6 (<85°C)
	Max. Power consumption:	2400 mW at 30 Vdc
	Max. Internal capacitance:	450 pF
	Internal inductance:	negligible

DECLARATION OF CONFORMITY
We DATASENSOR S.p.A. declare under our sole responsibility that these products are conform to the 2004/108/CE, 2006/95/CE Directives and successive amendments.

WARRANTY
DATASENSOR S.p.A. warrants its products to be free from defects. DATASENSOR S.p.A. will repair or replace, free of charge, any product found to be defective during the warranty period of 36 months from the manufacturing date. This warranty does not cover damage or liability deriving from the improper application of DATASENSOR products.

DATASENSOR S.p.A. Via Lavino 265
40050 Monte S. Pietro - Bologna - Italy
Tel: +39 051 6785611 Fax: +39 051 6759324
http://www.datasensor.com e-mail: info@datasensor.com

DATASENSOR S.p.A. cares for the environment: 100% recycled paper. DATASENSOR S.p.A. reserves the right to make modifications and improvements without prior notification.



TL46-WLF Contrast sensor

INSTRUCTION MANUAL

CONTROLS

OUT LED (yellow)

The yellow LED indicates the output status.

DISPLAY (green 4-digit display)

During normal functioning, the display indicates a value relative to the light quantity diffused by the target.

READY LED (RDY)

The green READY LED ON indicates a normal operating condition where the received signal has a safety margin respect to the output switching value: stability condition.

DELAY LED

The green DELAY LED ON indicates the timing activation on the digital output.

KEYLOCK LED

The green KEYLOCK LED ON indicates the active keyboard status.

(SET) (white), (+) (red), and (-) (green) PUSH-BUTTONS

See the "SETTING" paragraph for the correct adjustment phase indications.



INSTALLATION

The sensor can be positioned by means of the two Ø3.5mm housing's holes using or threaded M5 holes with 6mm max. depth.

Warning: the use of excessively long screws can damage the product.

The connector can be oriented at five different positions by rotating the block. The position chosen is guaranteed by a mechanical blocking system.

The rotation can be carried-out even after sensor installation as the connector block is completely self-contained inside the housing.



The operating distance is measured starting from the lens front face.

The reading direction can be changed inverting the cap and lens.

Mark detection on a reflective surface is improved adjusting the beam direction to 5° ... 20° from surface axis.



CONNECTIONS

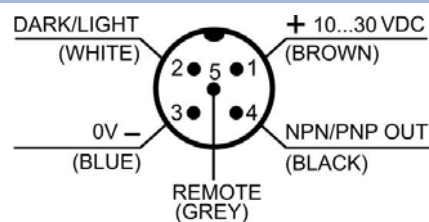

DIMENSIONS

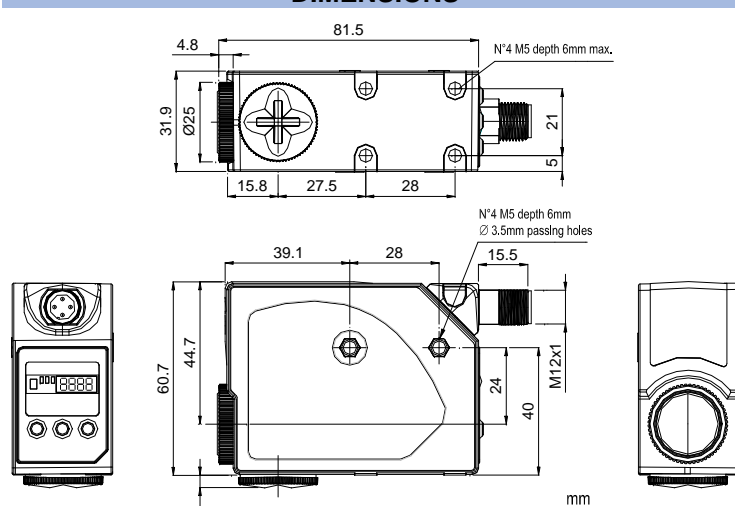

TECHNICAL DATA

Power supply:	10...30 Vdc limit values
Ripple:	2 Vpp max.
Current consumption (output current excluded):	35 mA max. @ 24 Vdc
Output:	1 selectable PNP/NPN output 30 Vdc max. (short-circuit protection) default PNP configuration
Output current:	100 mA max.
Output saturation voltage:	≤ 2 V
Response time:	16 μs
Switching frequency:	30 kHz
Indicators:	4-digit display (GREEN) / OUT LED (YELLOW) / READY LED (GREEN) / DELAY LED (GREEN) / KEYLOCK LED (GREEN)
Push-buttons:	push-buttons: -, SET, +
Delay	0...100 ms programmed default configuration without delay
Dark/light selection:	Automatic in the target/background detection selectable via wire in the dynamic detection
Operating temperature:	-10 ... 55 °C
Storage temperature:	-20 ... 70 °C
Electric shock protection:	double insulation
Operating distance:	9 mm
Depth of field:	± 3 mm
Minimum spot dimension:	1.5x5 mm
Emission type:	blue (465 nm) / green (520 nm) / red (630 nm) with automatic selection
Ambient light rejection:	according to EN 60947-5-2
Vibrations:	0.5 mm amplitude, 10 ... 55 Hz frequency, for each axis (EN60068-2-6)
Shock resistance:	11 ms (30 G) 6 shocks for each axis (EN60068-2-27)
Housing material:	Aluminium
Lens material:	Glass (*)
Mechanical protection:	IP67
Connections:	M12 5-pole connector
Weight:	170 g. max.

(*) It's available on request, PMMA plastic lens with 9mm focus.

SETTING

KEYLOCK FUNCTION (PATENT-COVERED)

The KEYLOCK function deactivates the keyboard avoiding any accidental changes in sensor setting.

At sensor powering, the keyboard is blocked (KEYLOCK LED OFF).

The (SET) push-button has to be pressed for 5 sec. until the KEYLOCK LED turns ON. The keyboard is blocked automatically if not used for 2 minutes.

The keyboard has to be unlocked to proceed with sensor setting.



DETECTION (MARK-BACKGROUND)

- Position mark in front of the sensor light spot and press the (SET) push-button until the 'SEt1' text appears.

The sensor detects the mark alternating the red, green and blue emissions.

Avoid mark movements until the 'SEt2' text appears and the OUT LED blinking.

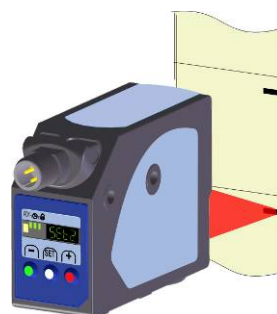

- Position the background in front of the sensor light spot and press the (SET) push-button again. The sensor detects the background and automatically selects the best emission to detect the contrast.

Avoid background movements during this phase.

The DARK/LIGHT operating mode is automatically selected by the sensor.

Dark mark - light background → dark mode;
light mark - dark background → light mode.

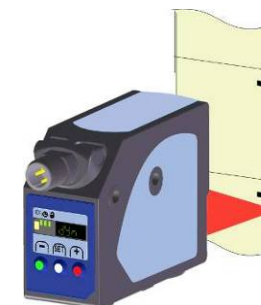

If the detection has been successful, the sensor returns to normal functioning. If it fails due to insufficient contrast, the 'FAIL' test blinks on the display. Press the (SET) push-button and the sensor returns to the previous setting.

Repeat the procedure from the beginning.



DYNAMIC SETTING

Use the dynamic setting to detect moving target. The sensor sets automatically the threshold value during target movement. The DARK/LIGHT mode has to be previously set. To select the light mode connect the DARK/LIGHT signal (white wire) to 0V or leave unconnected. To select the dark mode connect the DARK/LIGHT signal to the power supply.

- Position the sensor spot in front of the target to detect. Press (SET) until the 'dYn' text blinks (4sec) and keep it pressed. The sensor detects the mark and automatically selects the best emission to detect the contrast.

- To end the dynamic detection procedure release the (SET) push-button.

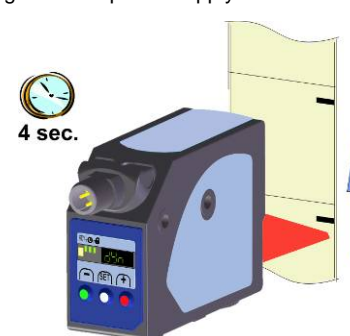

If the detection has been successful, the sensor returns to normal functioning. If it fails due to insufficient contrast, the 'Lo' test blinks on the display. Press the (SET) push-button to repeat procedure until releasing the button (the 'dYn' text blinks on the display). The sensor returns to the previous setting by pressing (+) or (-).



SWITCHING THRESHOLD SETTING

The sensor switching threshold can be adjusted in this manner.

The 'AdJ' text appears pressing (+) on the display. Releasing the push-button, the threshold value blinks.



The switching threshold is increased or reduced by pressing (+) or (-). Press (SET) to save the new threshold value.

HYSTERESIS SETTING

The sensor hysteresis level is adjusted.

The 'HYSt' text appears pressing green (-) on the display.



Releasing the push-button the previously set value blinks.

HIGH HYSTERESIS



NORMAL HYSTERESIS



LOW HYSTERESIS



The level switches by pressing (+) or (-).

Press (SET) to save the new hysteresis value.

OUTPUT OVERLOAD

The overload of the digital output is signalled by the '_SC_' text on the display. The sensor return to normal working when the overload condition disappears.



PARAMETER SETTING

Some parameters can be changed entering in the menu: DELAY ON, DELAY OFF, PNP/NPN switching output, display orientation and powering on/off of the display.

Press (+) and (-) contemporarily until the 'Menu' text appears.



Releasing the push-button, the first Delay ON parameter appears.

The parameter list is visualised by pressing (+) and (-):

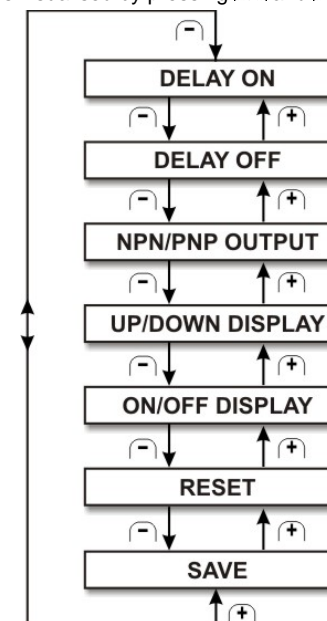

DELAY ON setting

The DELAY ON represents the output delay activation after the reference mark has entered in the detection area. The delay avoids the detection of events that occur rapidly. An example can be a mark with shaded colours (light-dark-light) that can be detected twice.

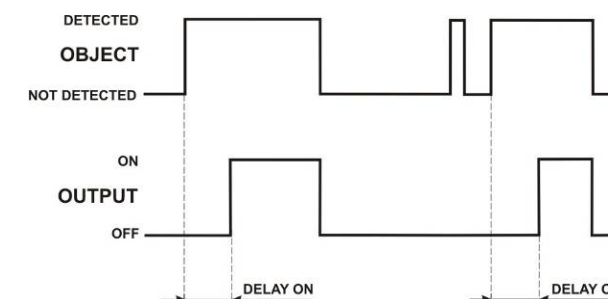

Select "dOn" in the parameter menu to set the DELAY ON function.

The parameter programming is accessed by pressing (SET). The previously set delay value appears on the display.



Pressing (+) or (-) the delay value is increased or decreased by one step of 1 ms until a maximum delay of 100ms. Keeping press (+) or (-) the delay value is increased or decreased by incremental step. The setting of a delay different from zero is signalled by the DELAY LED on. Press (SET) to confirm the value and return to the parameter menu.

DELAY OFF setting

The DELAY OFF represents the output delay deactivation after the reference target has left the detection area.

The delay extends the output activation allowing slower system interfacing with sensors to detect shorter pulses.

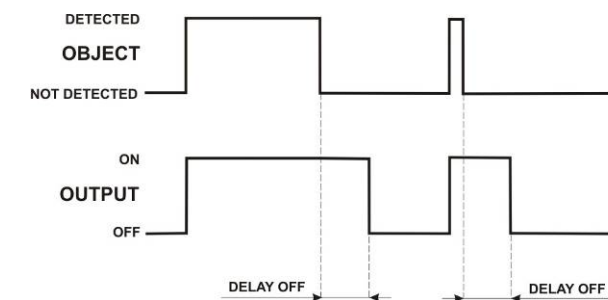

Select "dLOF" from the parameter menu to set DELAY OFF function.

The parameter programming is accessed by pressing (SET). The previously set delay value appears on the display.



Pressing (+) or (-) the delay value is increased or decreased by one step of 1 ms until a maximum delay of 100ms. Keeping press (+) or (-) the delay value is increased or decreased by incremental step. The setting of a delay different from zero is signalled by the DELAY LED on. Press (SET) to confirm the value and return to the parameter menu.

PNP/NPN output setting

The digital output can be configured as PNP or NPN. Select '_nPn' or '_nPN' in the parameter menu to switch the output.



The previously set output switches by pressing (SET).

UP/DOWN DISPLAY setting

The selection of the UP/DOWN display sets the reading direction on the display. Select "dSUP" or "dSdn" in the parameter menu to set the UP or DOWN direction.



Press (SET) to switch the reading direction previously set.

ON/OFF DISPLAY setting

Turn off the display during normally working to save power consumption. Setting the OFF mode, when the sensor is functioning normally, the display is OFF. It turns on for 5s after a keyboard command. Select "dSON" or "dSOF" in the parameter menu to set the display ON or OFF.



Press (SET) to switch the display mode previously set.

RESET of default parameters

Select "rSEt" in the parameter menu to reset the default parameters.



The "rSEt" text blinks when pressing (SET).

Releasing the push-button the sensor returns to normal functioning. The default reset parameters are:

PARAMETER	DISPLAY	DESCRIPTION
Emission	—	Green
DARK/LIGHT mode	—	Light
Threshold	2050	2050
Hysteresis	HyNo	Medium (Normal)
Delay ON and OFF	d 0	Deactivated
Digital output	_nPn	PNP output
Display	dSON dSUP	Display UP ON

NOTE: if the parameters are reset before turning the sensor off, when repowered the "rSEt" text blinks on the display for 3s before returning to normal visualisation.

Saving parameter set - "SAVE"

Select "SAVE" to save the parameter setting



The parameters are saved pressing (SET) and releasing it the display returns to normal visualisation.

NOTE: Set the data, the operator exits from the menu using the "SAVE" or "RESET" function. If these operations are not carried-out 30s after the last setting, the sensor returns to normal mode saving the parameters changed.

ACCESSORY FUNCTIONS

REMOTE INPUT

The REMOTE signals carries-out the acquisition functions without using the (SET) push-button.

The REMOTE wire connected to +Vdc is equal to pressing the (SET) push-button. Whereas, if the REMOTE wire is connected to GND or not connected it is equal to not pressing the (SET) push-button.

REMOTE	(SET) PUSH-BUTTON
0V	NOT PRESSED
+Vdc	PRESSED

- The duration of the REMOTE wire connection to +Vdc determines the acquisition type:

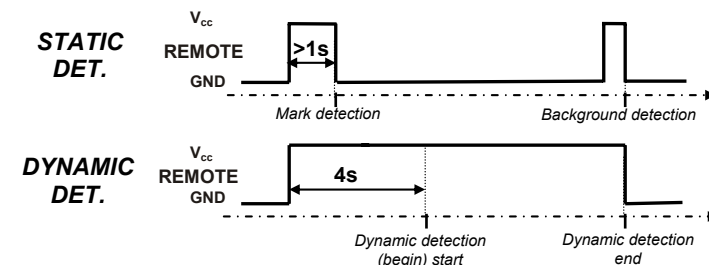

DARK/LIGHT input

The DARK/LIGHT signal allows the operator to select the DARK/LIGHT operating mode for dynamic detection. In the LIGHT mode the output is active with light marks on dark backgrounds, in the DARK mode the output is active with dark marks on light backgrounds. The connection of the DARK/LIGHT wire to Vdc sets the DARK mode. If connected to 0V or not connected set the LIGHT mode.

DARK/LIGHT	MODE
0V	LIGHT
+Vdc	DARK

	EX-II-3DG IP67 T6
	Temperature class: T6 (<85°C)
	Max. Power consumption 1000 mW at 30 Vdc
	Max. Internal capacitance 100 nF
	Internal inductance: negligible

DECLARATION OF CONFORMITY

We DATASENSOR S.p.A. declare under our sole responsibility that these products are conform to the 2004/108 CEE, 73/23 CEE Directives and successive amendments.

WARRANTY

DATASENSOR S.p.A. warrants its products to be free from defects. DATASENSOR S.p.A. will repair or replace, free of charge, any product found to be defective during the warranty period of 36 months from the manufacturing date. This warranty does not cover damage or liability deriving from the improper application of DATASENSOR products.

DATASENSOR S.p.A. Via Lavino 265
 40050 Monte S. Pietro - Bologna - Italy
 Tel: +39 051 6765611 Fax: +39 051 6759324
 http://www.datasensor.com e-mail: info@datasensor.com

DATASENSOR S.p.A. cares for the environment: 100% recycled paper.
 DATASENSOR S.p.A. reserves the right to make modifications and improvements without prior notification.

